

hibon[®]

Silent Flow Plus





SF-Plus Blower and Vacuum Systems



Silent Flow Plus Range :

The Silent Flow Plus range is made up of a group of rotary lobe blowers designed to circulate air or neutral gases in a non-hazardous environment. This range is comprised of a wide choice of high and medium pressure models. It incorporates recent requirements of EPD (European Pressure Directive) and CE safety issues.

- For high-pressure applications, Silent Flow Plus blower packages are equipped with SN Series three-lobe blowers featuring internal Pulsation Dampers.
- For medium-pressure applications Silent Flow Plus blower packages are equipped with S2H series Two Lobe Blowers

Benefits

- Extended range gives optimum blower package selection capability for any duty
 - Flow Rates: 100 m³/h (60 cfm) up to 7900 m³/h (4600 cfm)
 - Differential pressure up to 1000 mbar (15 psig)
 - Vacuum up to 500 mbar absolute (15" Hg)
- High and Medium-pressure ranges to meet your needs.
- Package is totally CE compliant and silencers are EPD compliant.
- Reduced noise levels due to the efficient noise enclosure and a specially designed ventilation baffling system.
- Enclosure capable of operation at high ambient temperatures; hot- air extraction by means of a high capacity, electrically operated ventilation fan.
- Hinged doors as standard (sizes 1 to 3).
- The belt tension is adjusted automatically by the motor weight with pivot base.
- "Plug and Play" design, factory assembled package.
- Easy access to package, easy maintenance.
- Each package is designed and built to ensure the smallest foot print.

Applications

- Water treatment aeration
- Pneumatic conveying
- Combustion Air
- Centralised Cleaning
- Fluidisation
- Homogenisation
- Gas Compression
- Oxidation Air
- Filter Scouring



Package components

■ Acoustic enclosure

The enclosure is built to withstand harsh weather conditions and ensure a long life. Forced ventilation is by a motorized fan unit. The acoustic material lining the walls is flame-retardant.

■ Installation

All blower packages are supplied fully assembled on a palletized base provided with a ground connection. The silencer base is connected to the base by a braided strap. The standard "Pressure" version packages have a pressure gauge connected to the discharge and an inlet filter restriction indicator.

■ Transmission

Silent Flow Plus packages are fitted with a Belt Pulley transmission. Our belt tensioning system allows automatic adjustment of the motor position. That mechanism permits the installation of motors of various designs and masses (iron and light alloy enclosures, NEMA standards, IEEE 841, etc). Following the first start-up, you will save maintenance time on Subsequent Belt/ Pulley adjustments.

■ The suction filter-silencer

Combines sound attenuation and filtering functions. Filtration protects blowers against premature wear and tear. The silencer dampens pulsations and reduces noise to your local sound environment.

■ Silencer base

Rests on anti-vibration mounts to reduce dynamic forces, it supports the blower/motor assembly, and inlet filter silencer. The design is totally reactive to ensure a broad spectrum sound attenuation without risk of fibrous migration to the downstream process.

■ Discharge Assembly

Comprising of a pipe fitted with a factory-calibrated safety relief valve isolated pressure gauge, check valve and a flexible connector.

■ The blowers

- For high-pressure applications, Silent Flow Plus HP packages are fitted with SN Series Three lobe blowers featuring Internal Pulsation Dampers.
- For medium-pressure applications, Silent Flow Plus MP packages are fitted with S2H Series.

■ Starting valve / Unloading valve (optional)

This device prevents high inrush on your power network when starting the motor. It is often necessary for star/delta starting.

■ Check valve

Made of aluminium and santoprene, this valve is totally corrosion-proof. The full bore minimizes pressure losses.

■ Oil change

The high-pressure range blowers come with an oil change system consisting of two check valves with internal pistons and safety caps (one per housing).

■ Options (Standard)

- Temperature gauge at discharge
- Temperature switch at discharge
- Thermostat inside the enclosure
- Pressure switch at discharge

■ Options (Non-standard)

- Discharge pressure switch
- Vacuum switch
- Filter differential switch
- Anti Condensation heaters
- Motor PTC Thermistors

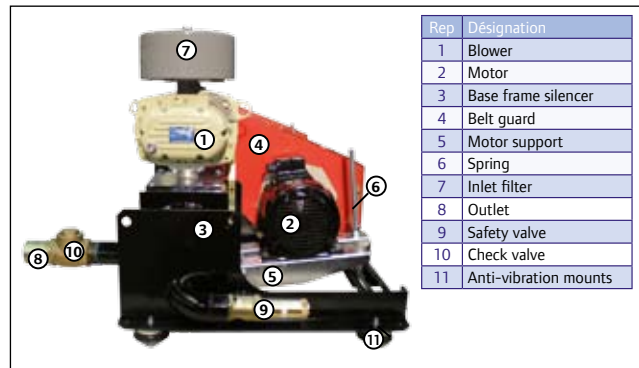

Performance

For high-pressure applications, Silent Flow Plus HP packages are fitted with three lobe blowers featuring Internal Pulsation Dampers. There are 12 units in the SN Series tri-lobe range covering flow rates up to 7900 m³/h (4600 cfm) at a differential pressure of 1000 mbar (15 psig) max or a vacuum of 500 mbar (15"Hg) max.

For medium-pressure applications, Silent Flow Plus MP packages are fitted with two lobe blowers. There are 4 units covering flow rates up to 900 m³/h (530 cfm) at a differential pressure of 700 mbar (10 psig) max or a vacuum of 500 mbar (15"Hg) max.

High Pressure range

Size	00		0			1			2			3			4		5											
 Silentflow PLUS	SF PLUS	H 00/1	SF PLUS	H 0/2	SF PLUS	H 0/3	SF PLUS	H 1/4	SF PLUS	H 1/6	SF PLUS	H 2/6	SF PLUS	H 2/11	SF PLUS	H 2/17	SF PLUS	H 3/22	SF PLUS	H 3/25	SF PLUS	H 3/42	SF PLUS	H 4/55	SF PLUS	H 4/70	SF PLUS	H 5/90
	Max Flow* m ³ /h cfm	300 180	460 270	650 380	830 500	1000 6000	1250 730	2300 1400	2500 1500	4050** 2400**	3700 2200	4200 2500	6000 3600	6400 3800	7900 4600													
Max Pressure. in mbar / in psig	1000 14,5	1000 14,5	1100 16	1000 14,5	1100 16	1100 16	1000 14,5	1000 14,5	800 11,5	1100 16	930 13,5	1000 14,5	900 13	900 13														
	Blowers	SN 801	SN 802	SN 803	SN 804	SN 806	SN 806	SN 811	SN 817	SN 822	SN 825	SN 842	SN 855	SN 870	SN 890													

* at 800 mbar eff / 11,5 psig

** at 700 mbar eff / 10 psig

Medium Pressure range

Size	00		0									
 Silentflow PLUS	SF PLUS	M 00/0.5	SF PLUS	M 00/1.5	SF PLUS	M 0/1.5	SF PLUS	M 0/3.5	SF PLUS	M 0/5.5	SF PLUS	M 0/5.5
	Max Flow* m ³ /h cfm	100 60	300 170	325 190	600 350	650 380	900 530					
Max Pressure. in mbar / in psig	700 10	700 10	700 10	620 9	620 9	550 8						
	Blowers	S2H22	S2H32	S2H32	S2H42	S2H52	S2H52					

* at 500 mbar eff / 7 psig

Silent Flow Plus Overall Dimensions

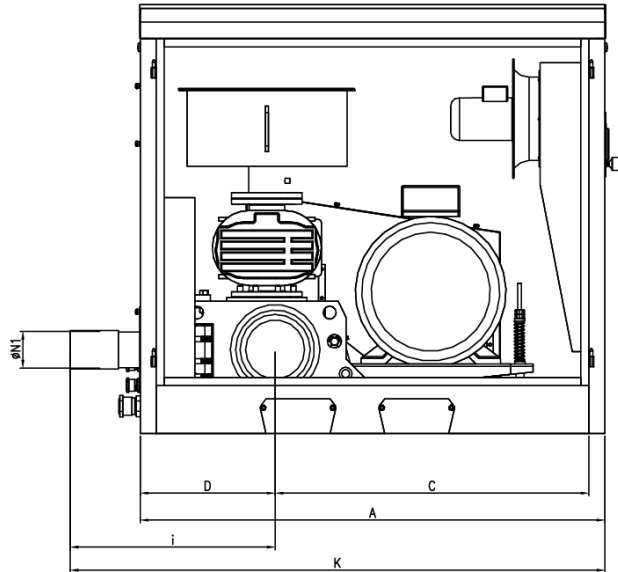
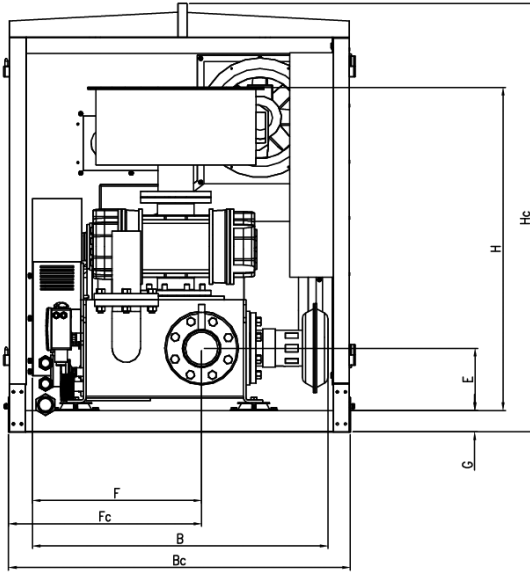

With enclosure

Type	A (mm/inch)	B	Bc	E	F	Fc	G	H (max)	Hc	K
SF PLUS H/M 00	770	595	720	163	413	480	40	770	850	812
	30" 1/3	23" 3/7	28" 1/3	6" 3/7	16" 1/4	18" 8/9	1" 4/7	30" 1/3	33" 1/2	32"
SF PLUS H/M 0	1200	831	1000	180	565	650	50	1014	1210	1295
	47" 1/4	32" 5/7	39" 3/8	7"	22" 1/4	25" 3/5	2"	40"	47" 2/3	51"
SF PLUS H 1	1450	921	1066	194	528	602	67	1131	1336	1668
	57"	36" 1/4	42"	7" 2/3	20" 4/5	23" 5/7	2" 2/3	44" 1/2	52" 3/5	65" 2/3
SF PLUS H 2	1730	1128	1405	230	640	852	67	1236	1526	2062
	68" 1/9	44" 2/5	55" 1/3	9"	25" 1/5	33" 1/2	2" 2/3	48" 2/3	60"	81" 1/6
SF PLUS H 3	2100	1305	1677	275	721	961	67	1535	1815	2404
	82" 2/3	51" 3/8	66"	10" 5/6	28" 2/5	37" 5/6	2" 2/3	60" 3/7	71" 1/2	94" 2/3
SF PLUS H 4	2500	1445	1800	320	765	900	100	1900	2600	3435
	98" 3/7	56" 8/9	70" 6/7	12" 3/5	30" 1/8	35" 3/7	4"	74" 4/5	102" 1/3	135" 1/4
SF PLUS H 5	2135	1980	2260	472	525	630	180	2410	2795	3206
	84"	78"	89"	18" 4/7	20" 2/3	24" 4/5	7"	94" 7/8	110"	126" 2/9

Service Center

Service Exchange - Maintenance & Service - Service Contract

All repairs and service are done in conformity with the highest industrial standards and completed by a team of experienced technicians and engineers. IR embraces its responsibilities to operate in a manner that protects the environment and human health and safety in order to support the company's long-term growth and reputation as a responsible corporate citizen.

SERVICE EXCHANGE

Guarantee your production capability

- Fast dispatch of the exchange machine
- Large range of machines ready to ship
- Performance certified as identical to your original machine
- 12-month warranty
- Price includes the return of your blower

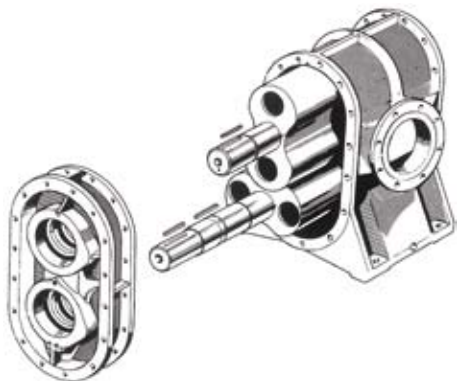

ON-SITE TECHNICAL SUPPORT

Bring our expertise to you

- Installation, commissioning, service, and maintenance on-site
- Diagnostic and breakdown service
- Qualified technical service with the full support of our technical department



MAINTENANCE & SERVICE

To your original specifications

- More than 100 years of technical and industrial experience
- Cleaning system keeping the component integrity
- Spare parts with supplier warranty (over 20 000 parts in stock)
- Available for standard service
- Guarantee on the quoted lead-time
- Similar test as a new machine
- Technical survey in link with our technical department
- Expertise and application recommendation available on demand



SERVICE CONTRACTS





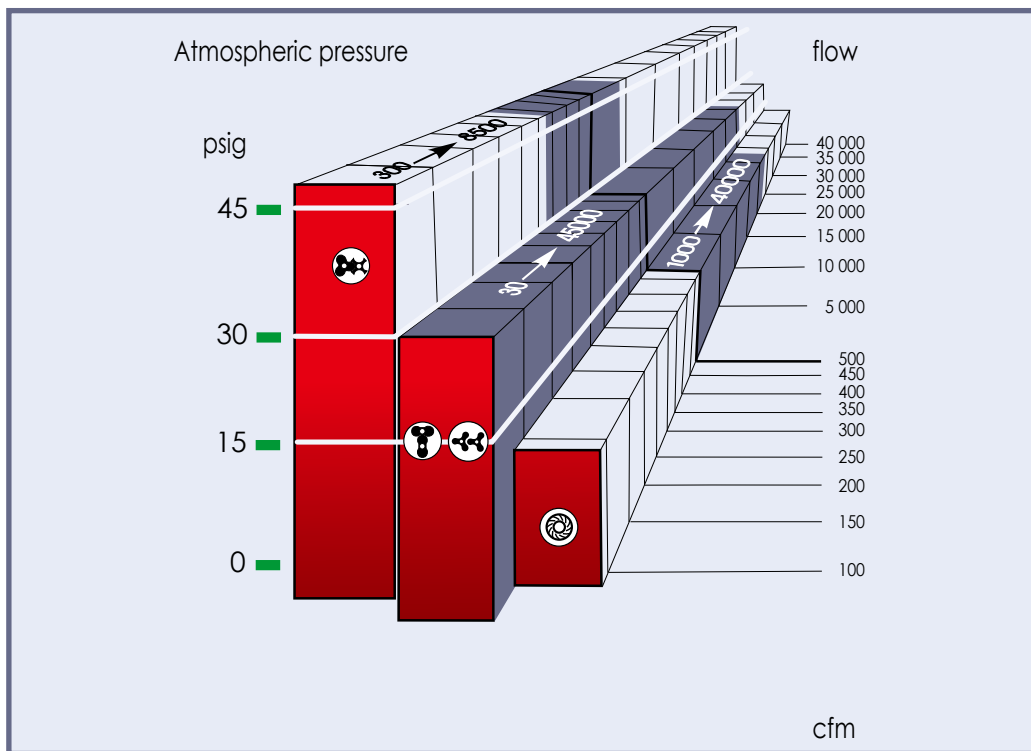

Maximize uptime

- Keep costs under control
- Personal contract possibilities
- Scheduled maintenance
- Priority service in an outage
- Reduce downtime



Other Solutions



	<p>Standard positive displacement blowers (bi-lobe and tri-lobe)</p>	
	<p>Multistage Centrifugal Blowers</p>	
	<p>Oil Free Screw Compressors</p>	



Ingersoll Rand Industrial Technologies provides products, services and solutions to enhance the efficiency and productivity of our commercial, industrial and process customers. Our innovative products include air compressors, air systems components, tools, pumps, material and fluid handling systems and microturbines.

Hibon Inc
(An Ingersoll Rand Company)
12055 Cote de Liesse
Dorval Quebec
Canada, H9P 1B4
Tel : (514) 631-3501
Fax : (514) 631-3502

Davidson IR
800 Beaty St
Davidson, NC 28036
USA

www.ingersollrand.com
www.hibon.com

Ingersoll Rand Air Solutions France
2 av. Jean Paul Sartre
59 290 Wasquehal
France
Tél : (33) 03 20 45 39 39
Fax : (33) 03 20 45 39 97

Low Pressure Business Unit / Air Solutions
11F Tower B, City Center of Shanghai,
No. 100 Zun Yi Road,
200051, Shanghai P.R.C.

Ingersoll Rand compressors are not designed, intended or approved for breathing air applications. Ingersoll Rand does not approve specialized equipment for breathing air application and assumes no responsibility or liability for compressors used for breathing air service.

Nothing contained on these pages is intended to extend any warranty or representation, expressed or implied, regarding the product described herein. Any such warranties or other terms and conditions of sale of products shall be in accordance with Ingersoll Rand's standard terms and conditions of sale for such products, which are available upon request.

Product improvement is a continuing goal at Ingersoll Rand. Designs and specifications are subject to change without notice or obligation.